

Pi^π Technical Note 38

Airflush

Introduction

The Process Instruments Airflush provides compressed air for automatic cleaning of compatible sensors, including Dissolved Oxygen, pH3 and ORP3. Only requiring power (80..264 VAC, 47..63Hz or 113..370 VDC), the self-contained unit provides compressed air on demand at the sensor installation site, removing the requirement of running pneumatic lines to the installation. The Airflush unit is controlled by the CRIUS® or CRONOS® analyser using a firmware auto-clean process control module. The analyser will initiate cleaning of the sensor at user-defined intervals whilst holding the sensor output during the cleaning cycle to prevent spurious data appearing in the data trend or perturbing an associated PID control output. The sensor can be configured to maintain the hold value for a user definable period following the cleaning cycle to allow the sensor values to recover.

Theory of Operation

When activated, the Airflush switches on an air pump and pressurises an air receiver. The air pressure in the receiver is monitored until it reaches a predefined threshold of approximately 5 bar. Once the threshold is passed, the Airflush opens a valve, allowing the air to flow out of the Airflush unit and clean the sensor. This initial blast of air is followed by a sustained stream of air as the air pump remains active until the clean signal is cleared by the analyser.

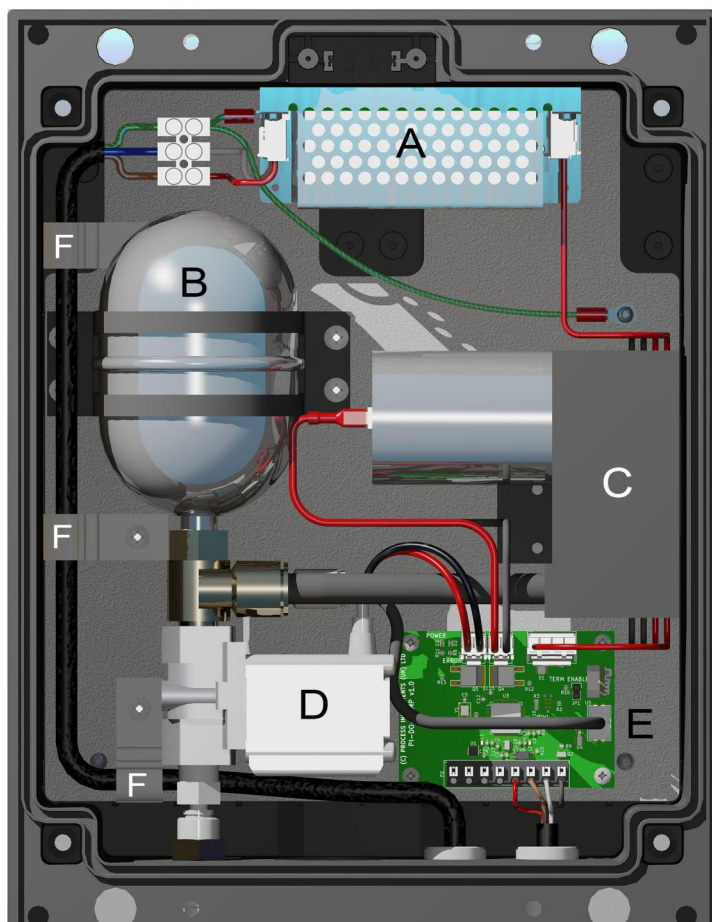

- A. Power supply*
- B. Air receiver*
- C. Air pump*
- D. Valve*
- E. Control electronics*
- F. Power cable routing clips*

Airflush internal layout

Installation

The Airflush enclosure is available in the same size and overlay design as the CRONOS® and CRIUS® analysers.

The Airflush should be mounted such that there is sufficient clearance to allow the compartment to be opened.

Wall Mounting

The Airflush enclosure can be screwed directly into a wall by marking and drilling holes on the reverse. Insert wall plugs and secure with appropriate screws (not supplied by Pi).

Handrail/Pole Mounting

The Airflush enclosure can be handrail mounted using a handrail mounting kit (available from Pi). By turning the handrail mounting brackets through 90°, the Airflush enclosure can also be pole mounted.

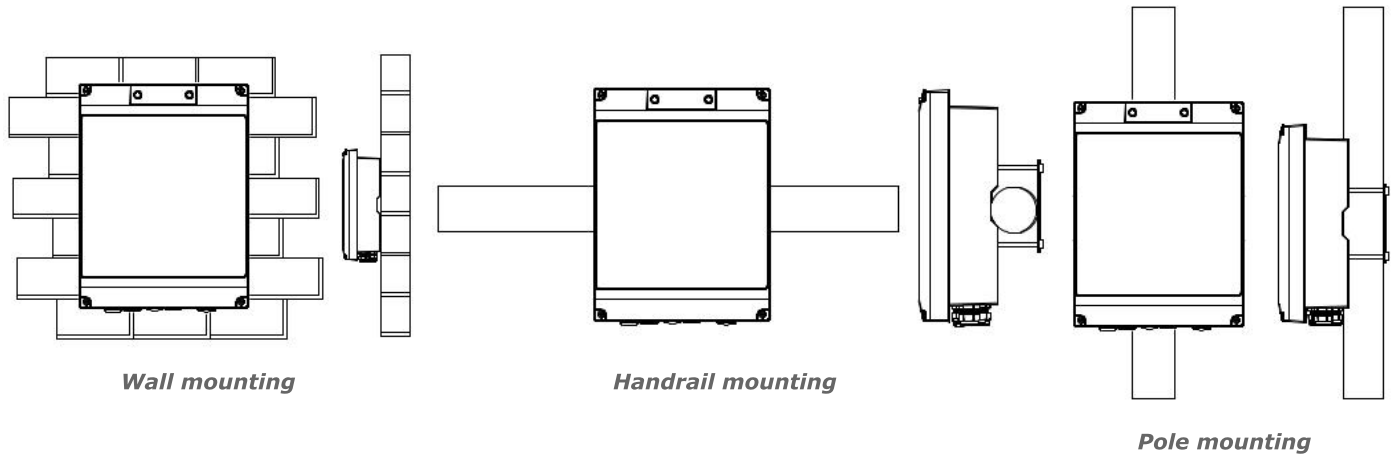

Connections

The start input for the Airflush should be connected to the CRIUS® relay outputting the Autoclean control. The error output can be monitored by connecting to a CRIUS® digital input.

The Airflush compressed air output should be connected to the sensor flush line connector using appropriate tubing. It is advised that a non-return valve is fitted as close as practicable to the sensor. This is to prevent sample water entering the flush line and depositing contamination, which may cause a blockage.



- A. Compressed air**
- B. Air filter**
- C. Mains power cable**
- D. Controls cable to CRONOS®/CRIUS®**

Airflush pneumatic connections

Auto-Verification of the OxySense

When combined with Process Instruments' dissolved oxygen sensor, OxySense, the Airflush can be used to verify that the sensor is functioning correctly on each cleaning cycle. For applications monitoring relatively low oxygen concentrations, for example, WWTW aeration lanes, the blast of cleaning air will cause a rise in the sensor readings. This change is monitored by the analyser to ensure that the sensor is responsive. The operator is notified if the sensor fails to respond as expected, allowing proactive maintenance before a sensor failure occurs.